

Connection Housings for Cartridge Valves

Standard Inline Bodies
Sandwich Bodies
Subplate Bodies

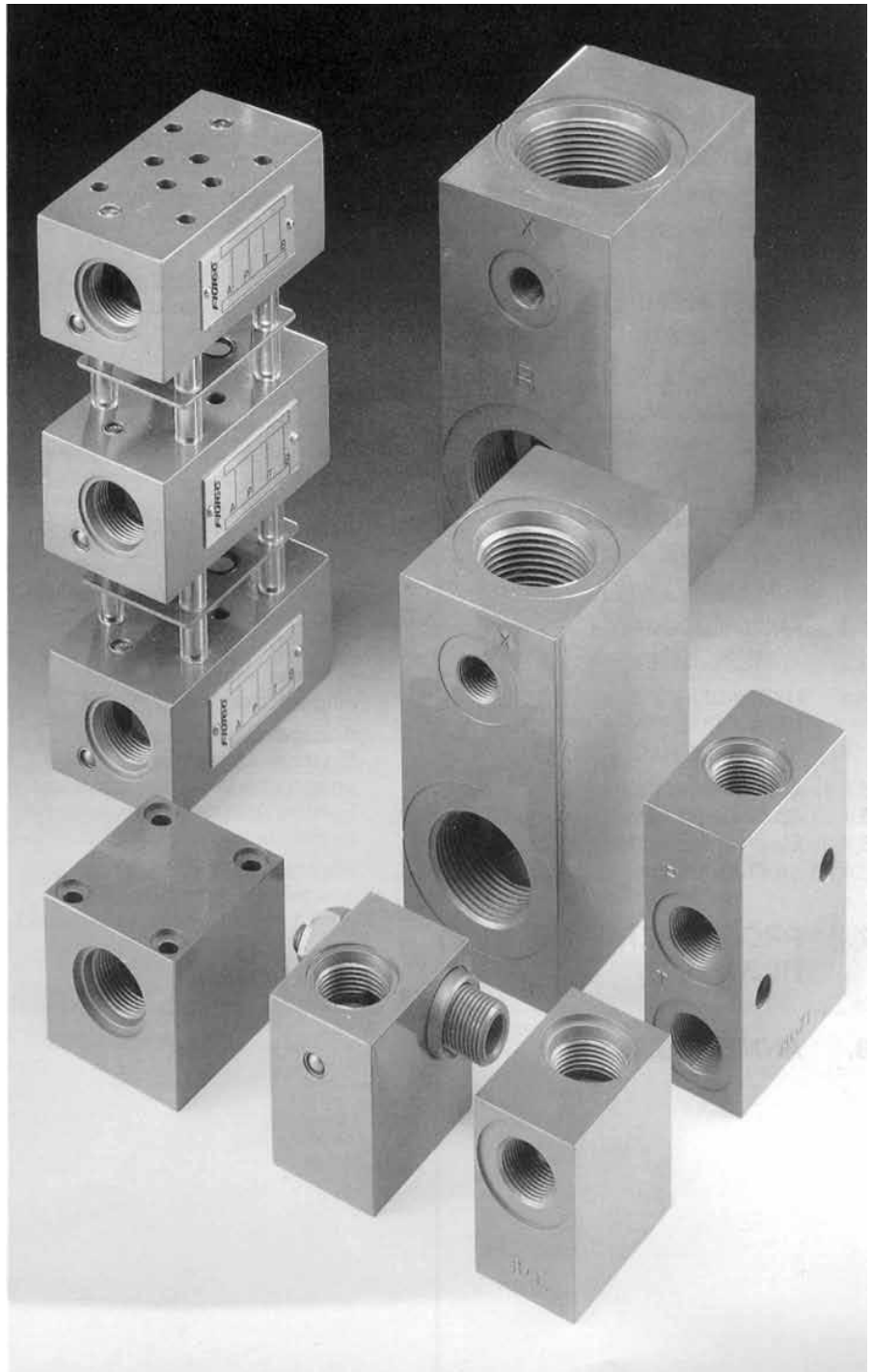
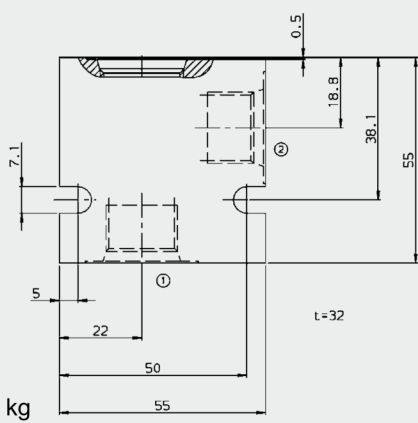
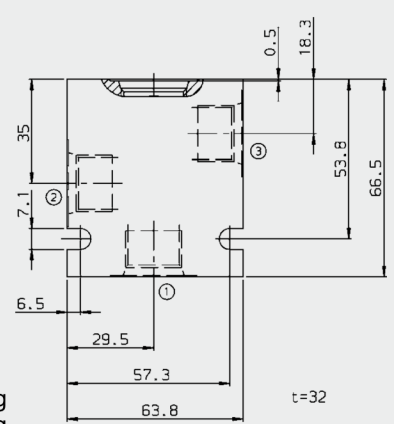
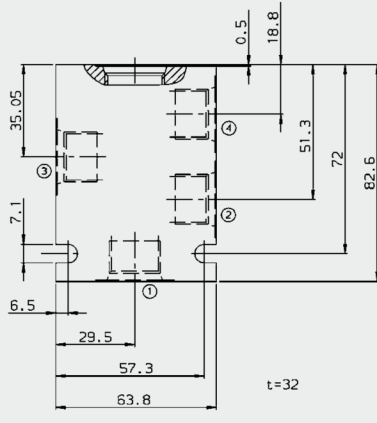
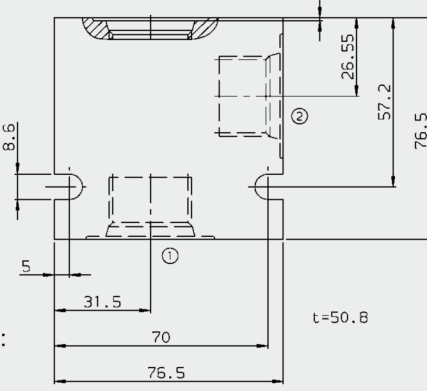

Part No.	Model Code	Thread Size	Dimensions	Cartridge valve	
				Type	Brochure / Data Sheet No.
3037777	FH102-AB4	① 1/2"BSP	 <p>Weight: Al: 0.20 kg St: 0.54 kg</p>	DP10P-01	5.954
3037594	FH102-SB4	② 1/2"BSP		RV10A-01	5.953
3037779	FH102-AN4	① 1/2"NPTF		SR10-01	5.958
3037599	FH102-SN4	② 1/2"NPTF		WS10Z-01	5.926
3037778	FH102-AS8	① SAE8		WS10ZR-01	5.927
3037612	FH102-SS8	② SAE8		WS10Y-01	5.914
				WS10YR-01	5.921
				WK10W-01	
				WK10V-01	
				SDR10A-01	5.988
				PDB10P-01	5.991
				SD10-01	5.989
3038092	FH103-AB4	① 1/2"BSP	 <p>Weight: Al: 0.26 kg St: 0.72 kg</p>	DR10-01	5.950
3037697	FH103-SB4	② 1/2"BSP		RP10A-01	5.932
		③ 1/2"BSP		WK10L-01	5.957
3038093	FH103-AN4	① 1/2"NPTF		WK10C-01	5.963
3037743	FH103-SN4	② 1/2"NPTF		WK10D-01	5.964
		③ 1/2"NPTF		WS10C-01	
3038095	FH103-AS8	① SAE8	WS10D-01		
3037704	FH103-SS8	② SAE8	DR10P-01	5.982	
		③ SAE8	PDR10P-01	5.990	
		③ SAE8	WK10C-40	5.995	
3038097	FH104-AB4	① 1/2"BSP	 <p>Weight: Al: 0.32 kg St: 0.88 kg</p>	WK10G-01	5.938
		② 1/2"BSP		WK10E-01	5.937
3037784	FH104-SB4	③ 1/2"BSP		WK10H-01	5.936
		④ 1/2"BSP		WK10J-01	5.939
3038109	FH104-AN4	① 1/2"NPTF		WK10Y-01	5.971
		② 1/2"NPTF		WK10X-01	5.961
3037932	FH104-SN4	③ 1/2"NPTF		WK10A-01	5.968
		④ 1/2"NPTF		WK10Z-01	5.960
3038110	FH104-AS8	① SAE8		WK10K-01	5.966
		② SAE8		WK10P-01	5.972
3037868	FH104-SS8	③ SAE8	WKH10C-01		
		④ SAE8	ST10-01	5.967	
			WK10R-01	5.962	
			WK10F-01		
3053843	FH122-AB6	① 3/4"BSP	 <p>Weight: Al: St:</p>	RV12A-01	5.952
3053782	FH122-SB6	② 3/4"BSP		WS12Z-01	5.998
3053845	FH122-AS12	① SAE12		WS12ZR-01	5.998.1
3053772	FH122-SS12	② SAE12		WS12Y-01	5.998.2
			WS12YR-01	5.998.3	
			DP12P-01	5.922.2	
			PDB12P-01	5.991.2	